

APPLICATION NOTE

ABSTRACT

This application note illustrates the use of an 87LPC76x microcontroller from Philips Semiconductors as an infrared RC5 remote control transmitter.

AN10210

Using the Philips 87LPC76x microcontroller as a remote control transmitter

Author: Paul Seerden

2003 Feb 10

Using the Philips 87LPC76x microcontroller as a remote control transmitter

AN10210

INTRODUCTION

The P87LPC760 is a 14-pin single chip microcontroller designed for applications demanding high-integration, low cost solutions over a wide range of performance requirements. It is based on an 80C51 processor architecture that executes instructions at twice the rate of standard 80C51 devices.

The P87LPC760 offers internal RC operation, wide operating voltage range, programmable I/O port configurations, LED drive outputs, two 16 bit timers, a build-in watchdog timer, four keypad interrupt inputs and power reduction modes.

All these features make the LPC760 very suitable for remote control transmitter applications. It is a very cost effective alternative for older or even discontinued devices like the PCA84C122 and the SAA3010.

HARDWARE

Figure 1 shows the main application of the P87LPC760 as a remote control transmitter. A 16-key pad, arranged as a 4 x 4 matrix, is implemented using only eight port pins of the microcontroller. The 'sense' (input) lines are connected to port 0. The

P87LPC760 allows any pin of port 0 to be enabled to cause a single keyboard interrupt. The interrupt is generated when any enabled pin is pulled low by a key pressure.

The 'scan' (output) lines are designated to port 1 pins of the LPC760. By making each scan line logic 0 in turn, and each time looking at the sense lines, a depressed key can be detected. Each key of the transmitter keypad represents a corresponding command code, determined by using a software look-up table. This code together with the system address (see next chapter) is sent according the RC5 protocol.

The pulses that are generated are available at port pin P1.7. This pin drives the output transistor, which provides the current for the IR-LED.

In our example, the on-chip reset and the micro's internal RC oscillator (6 MHz ±2.5%) are used.

Unused port pins could be used to expand the keypad matrix or for example to select the controllers system address. If more I/O or on-chip program (code) memory is needed alternative micro-controllers, like the P87LPC761/2 are available from Philips Semiconductors.

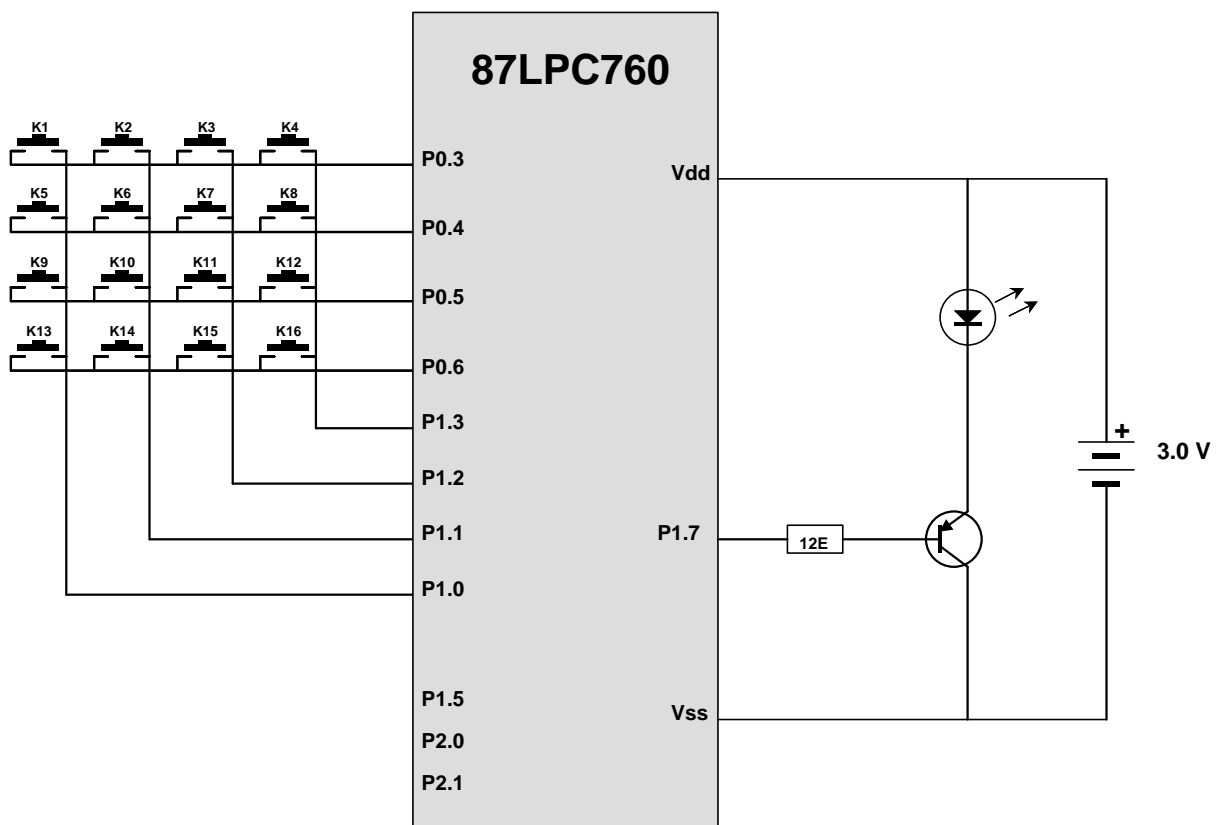

Fig. 1 P87LPC760 remote control transmitter application

Using the Philips 87LPC76x microcontroller as a remote control transmitter

AN10210

RC5 TRANSMISSION PROTOCOL

To ensure immunity to interference from other IR sources such as the sun, lamps and IR sound transmissions (to headphones), bi-phase encoding (also called Manchester encoding) is used for RC5 code words. As shown in figure 2 each bi-phase encoded bit is a symbol comprising two logic levels with a transition in the middle.

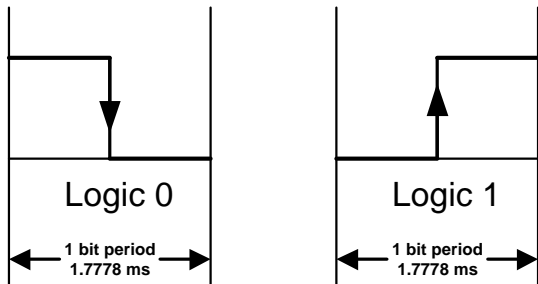

Fig. 2 Bi-phase code word bits

As shown in figure 3, the bi-phase code words modulate a 36 kHz carrier, before being transmitted via the IR LED. Since the repetition period of the 36 kHz carrier is 27.778 us and the duty factor is 25 %, the carrier pulse duration is 6.944 us. Because the high part of each bit of the RC5 code word contains 32 carrier pulses, 1 bit period is 64 x 27.778 us = 1.778 ms.

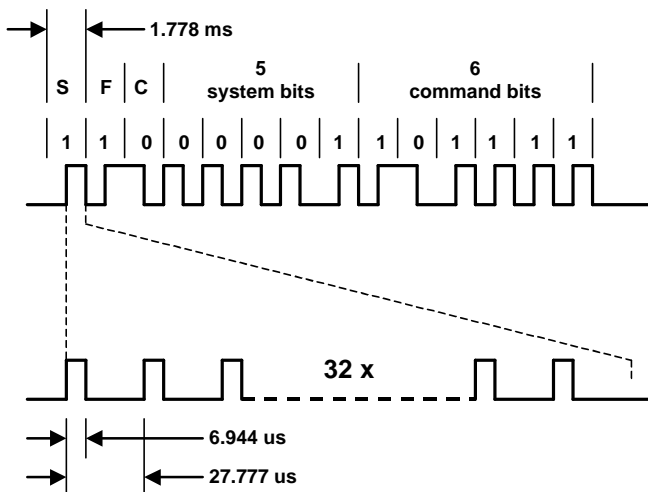

Fig. 3 RC5 code word example

A complete RC5 code word contains 14 bits, so it takes 24.889 ms to transmit. Each 14 bit RC5 code word consists of:

- a start bit (S) which is always logic 1
- a field bit (F) which denotes command codes 0 to 63 or 64 to 127
- a control bit (C) which toggles after each key release and initiates a new transmission
- five system address bits for selecting one of 32 possible systems
- six command bits representing one of the 128 possible RC5 commands

SOFTWARE

Main loop (see figure 4)

After initialisation of the hardware, the four scan-lines (port pins P1.0-3) are pulled low and the LPC76x is forced into power down mode.

If one of the 16 keys is pressed a keyboard interrupt will be generated and the micro will wake up from power down mode. The main program checks for a valid key hit. Next, the control bit (C) of the system byte is set or reset. After that, a routine is called for sending out the key info as an RC5 code word. Finally power down mode is entered again, waiting to wake up at the next keyboard or watchdog interrupt.

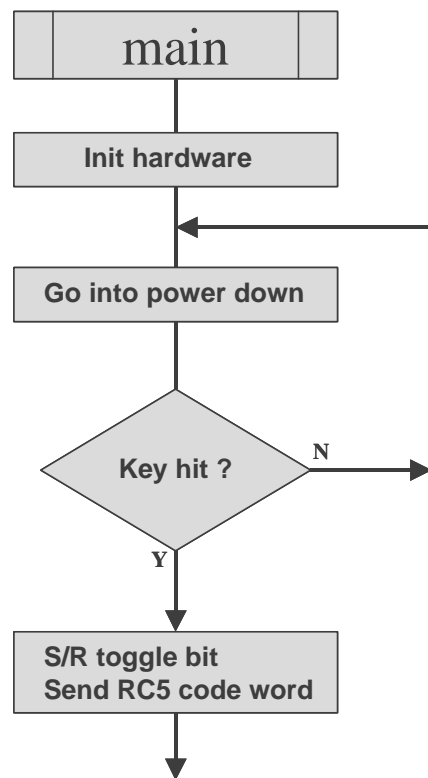

Fig. 4 Main software loop

Using the Philips 87LPC76x microcontroller as a remote control transmitter

AN10210

Keyboard Interrupt

When a key is pressed, an interrupt is generated. Inside the Keyboard Interrupt routine the keyboard interrupt is disabled and the de-bounce Timer 0 is started. This is done in order to let enough time (5 ms) for the key to stabilize so that we read a correct value from the port 0 sense lines. While waiting for the de-bounce timer to expire the micro is in idle mode to save power.

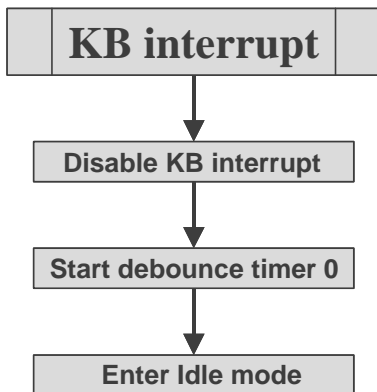

Timer 0 (de-bounce timer) Interrupt

At the very beginning of the Timer 0 interrupt routine, after the timer is stopped a routine is called to decode the keypad. After detection of a valid key pressure this routine sets / resets the flag "key hit" (see main loop).

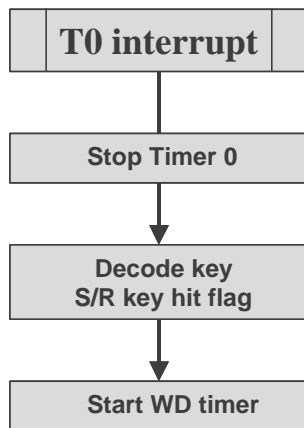

At the end of the timer interrupt the watchdog timer is started. This timer is used for repetition of sending RC5 code words (every 100 ms) as long as a key stays pressed.

Watchdog Timer Interrupt

If the watchdog timer overflows an interrupt is generated and the micro leaves power down mode (from inside the main loop). First the decode keyboard routine is called to check if a key is still pressed. If that is the case the watchdog is fed and the interrupt routine is left, resulting in sending a new RC5 command by the main loop and the next watchdog interrupt after approximately 100 ms.

If there is no more "key hit" (key released) the watchdog timer is stopped, the toggle bit is inverted and the keyboard interrupt is re-enabled. This results in the micro going back into power down mode, waiting for the next keyboard interrupt (key pressure).

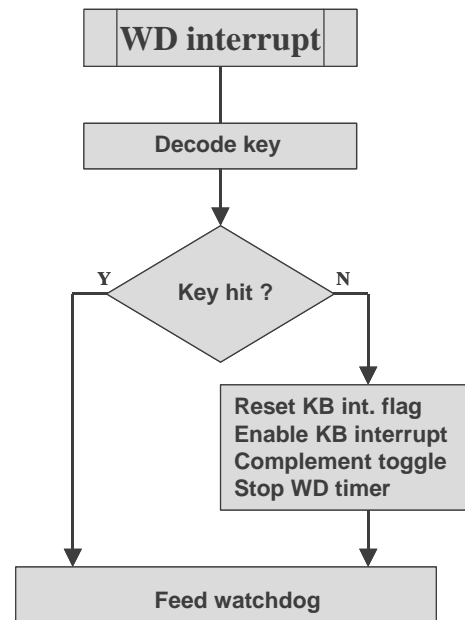

Send RC5 code word

The flow diagram below shows the routine used for sending out an RC5 code word. The program starts with setting a bit counter to 14 and sending the start bit. For sending out 36 KHz modulated bits the sub-routine "Start_Mod" is called which is described later on in this document.

After transmission of the start bit, the next 13 bits of the RC5 code word are transmitted, using the above-described Manchester encoding principle. After each bit transfer a delay of 889 microseconds is programmed using Timer 1 of the micro, according the RC5 specification. Then, the next two bits of the RC5 code word are checked to decide if a short (modulated) pulse, a long pulse or another extra delay should follow.

Using the Philips 87LPC76x microcontroller as a remote control transmitter

AN10210

If the bit counter reaches zero the program returns back to the main loop and the micro enters power down mode again.

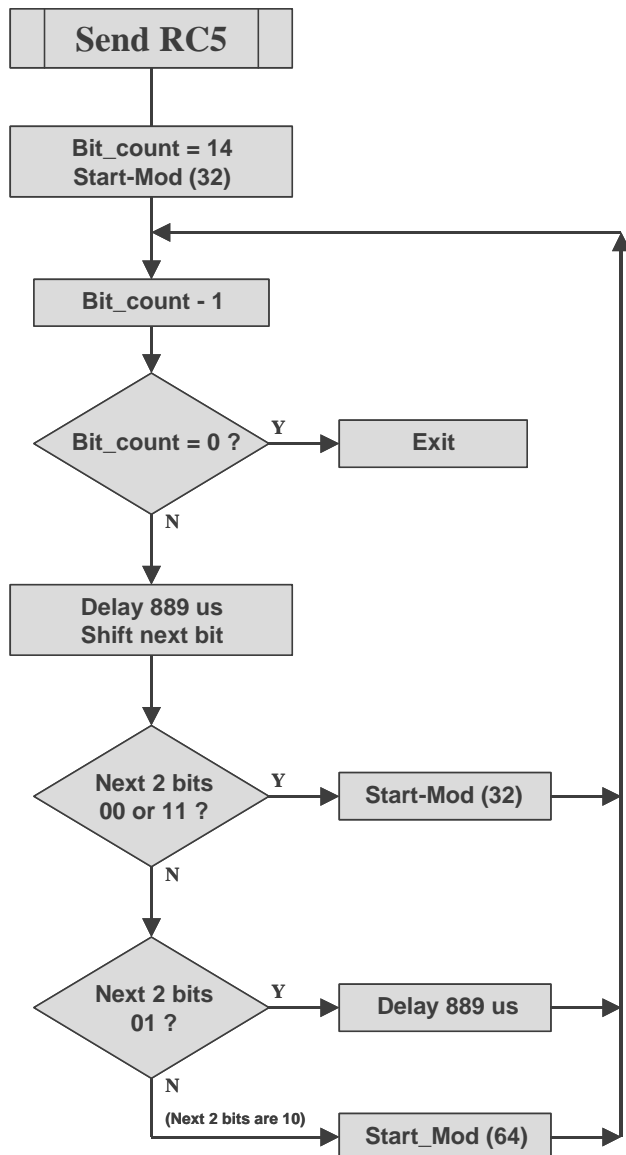

36 KHz modulator

For the generation of 32 (or 64) pulses modulated at 36 KHz with a duty cycle of 25% Timer 1 of the micro is used. This part of the program is very time critical and is therefore written in assembly.

T1 is programmed in auto-reload mode generating an interrupt every 27.777 us (including latency). Inside the interrupt routine a puls-counter is decremented and at port pin P1.7 a puls of 7 us is generated, according the RC5 specification.

SOURCE CODE

Code file of this application note can be made available on request. Please send an email to the Philips Semiconductors helpdesk at:

micro.support.europe@philips.com

REFERENCES

For further details please refer to the following publications:

- o Datasheets:
www.semiconductors.philips.com
- o "Remote control system RC-5"
doc. Nr: 9398 706 23011
- o AN10184: "Connecting a keyboard to the Philips LPC9xx microcontroller"
- o Example Programs:
<http://www.keil.com/download/c51.asp>

Low Cost 8051 μ C Starter Kit/ Development Board HT-MC-02

HT-MC-02 is an ideal platform for small to medium scale embedded systems development and quick 8051 embedded design prototyping. **HT-MC-02** can be used as stand-alone 8051 μ C Flash programmer or as a development, prototyping and educational platform

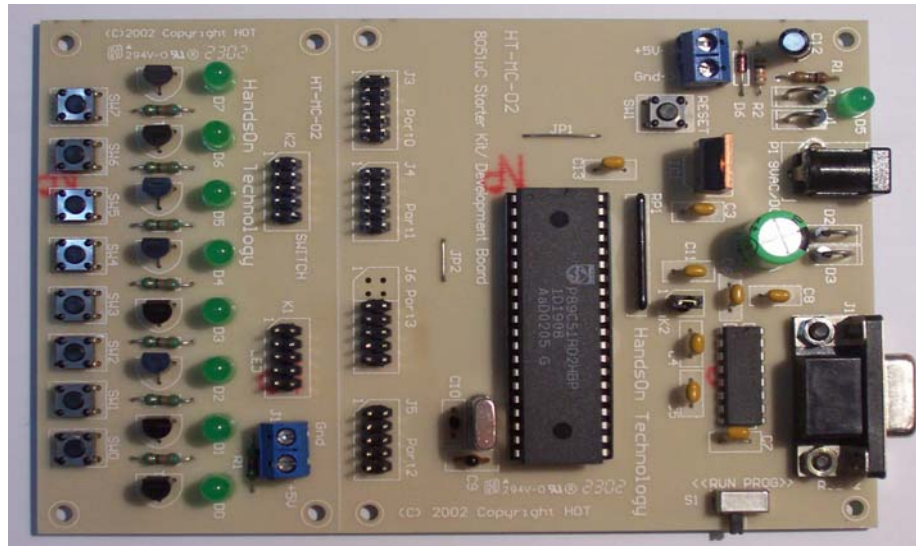

Main Features:

- 8051 Central Processing Unit.
- On-chip Flash Program Memory with In-System Programming (ISP) and In Application Programming (IAP) capability.
- Boot ROM contains low level Flash programming routines for downloading code via the RS232.
- Flash memory reliably stores program code even after 10,000 erase and program cycles.
- 10-year minimum data retention.
- Programmable security for the code in the Flash. The security feature protects against software piracy and prevents the contents of the Flash from being read.
- 4 level priority interrupt & 7 interrupt sources.
- 32 general purpose I/O pins connected to 10pins header connectors for easy I/O pins access.
- Full-duplex enhanced UART – Framing error detection Automatic address recognition.
- Programmable Counter Array (PCA) & Pulse Width Modulation (PWM).
- Three 16-bits timer/event counters.
- AC/DC (9~12V) power supply – easily available from wall socket power adapter.
- On board stabilized +5Vdc for other external interface circuit power supply.
- Included 8x LEDs and pushbuttons test board (free with **HT-MC-02** while stock last) for fast simple code testing.
- Industrial popular window **Keil C** compiler and assembler included (Eval. version).
- Free **Flash Magic** Windows software for easy program code down loading.

PLEASE READ **HT-MC-02 GETTING STARTED MANUAL** BEFORE OPERATE THIS BOARD
INSTALL ACROBAT READER (AcrobatReader705 Application) TO OPEN AND PRINT ALL DOCUMENTS